



Nano

The Nano series of bench top chambers are designed for testing relatively smaller sizes of specimen. With a small foot print, this chamber is capable of performing low, high temperature and humidity tests.



Parameters	Nano Bench Top Chambers	
	Nano-80-AH	Nano-19-AH
Work Space Volume (L) (mm)	80	19
Work Space (W x D x H) (mm)	400 x 400 x 500	300 x 250 x 250
Exterior (W x D x H) (mm)	625 x 1300 x 1000	475 x 575 x 800
Temperature Range (°C)	-30 to 85	-35 to 80
Ramp Rate (°C/Min)	1	1
Humidity Range (%RH)	10 to 95	NA

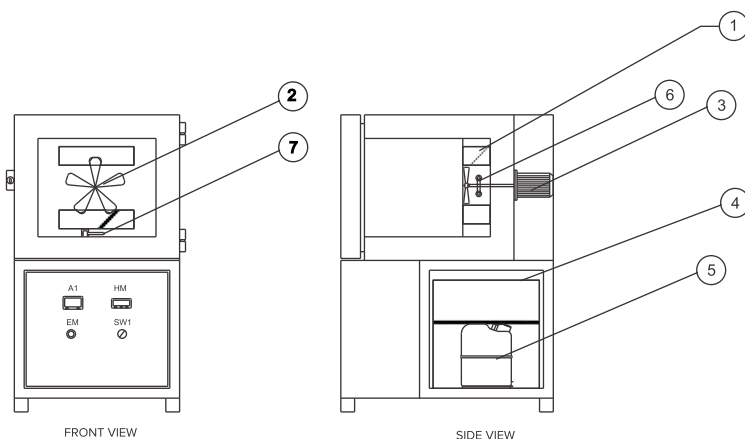

SL No	Descriptions
1	Evaporator
2	Fan blade
3	Fan motor
4	Condensor
5	Compressor
6	Air heater
7	Sensors

Small Footprint : The Nano series of bench top chambers are built compact even though they have all the test capabilities of larger chambers.

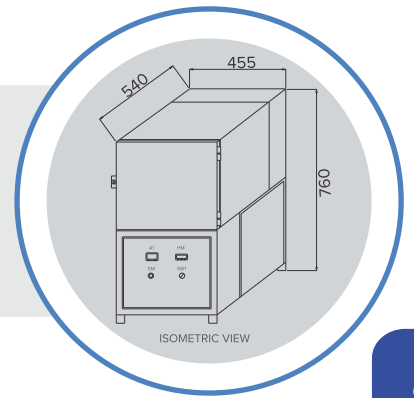

Precise Control : A PID based controller provides accurate and high stability for both temperature and humidity operation.

Conditioning System : The compact and highly reliable refrigeration system provides the necessary cooling demand, whereas the heaters provide the needed high temperature. The specially designed humidity systems takes care of the precise injecting and removal of humidity.



Inbuilt features : Multiple port holes, Adjustable shelves, Door limit switch and many more.

Designed to perform : The Nano series are designed to operate in the most demanding tropical environments. Chambers are provided air cooled condensers.



Global warranty of parts : All major components and sub-systems are of globally reputed brands. Which are available off the shelf, ensuring the lowest down time incase of any maintenance.